

HYPHERPRO

STEERING DAMPER MOUNTING KIT for APRILIA RSV1000 MILLE R Model 2006>

MK-AP10-0005 PART LIST

SD stroke 75	1	Washer M8 Ø 16	1
Tube Clamp TYPE 7	1	-	-
O-Ring	2	-	-
Fork clamp Ø 56	1	-	-
M6x30	1	-	-
M8x25 Button head	1	-	-
Washer M6 Ø 12	2	-	-
Washer M6 Ø 18	1	-	-

ALL IDEAS, DESIGNS ARRANGEMENTS AND PLANS INDICATED OR REPRESENTED BY THIS DRAWING ARE OWNED BY HYPERPRO AND WERE CREATED, EVOLVED AND DEVELOPED FOR USE ON AND IN CONNECTION WITH THE SPECIFIC PROJECT. NONE SUCH IDEAS, DESIGNS, ARRANGEMENTS OR PLANS SHALL BE USED BY OR DISCLOSED TO ANY PERSON, FIRM OR CORPORATION FOR ANY PURPOSE WHATSOEVER WITHOUT THE WRITTEN PERMISSION OF HYPERPRO.

DAMPING ADJUSTMENT KNOB:
- turn CW to increase damping
- turn CCW to decrease damping
NEVER USE MAXIMUM SETTING !!!

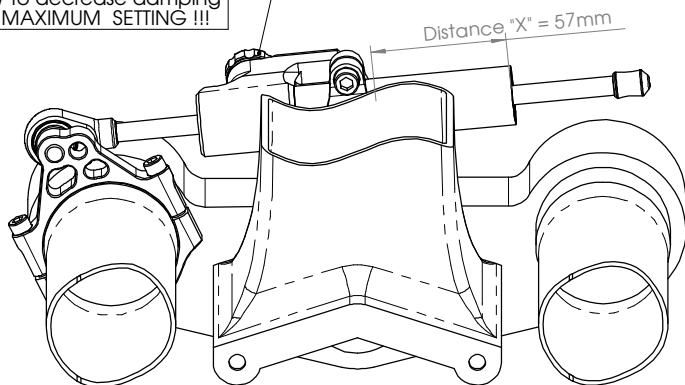

Steps 1&2

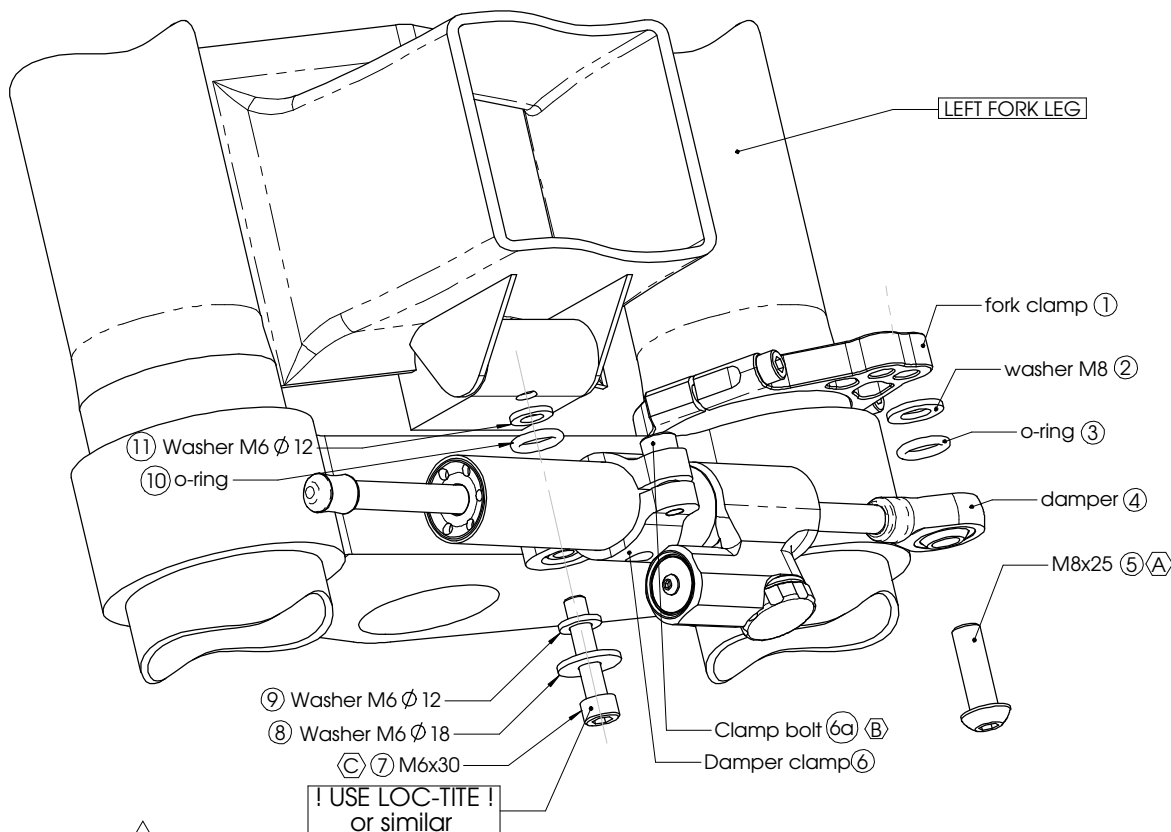

Set fork clamp parallel to riding direction when fork is turned fully to the Right.

Step 3

ⓐ clamp bolts

① fork clamp

1
of 2

A 14-17Nm / 124-150Lbs.In / 10.3-12.5Lbs.Ft

C 8Nm / 70Lbs.In / 5.9Lbs.Ft

B 6Nm / 53Lbs.In / 4.4Lbs.Ft

See WWW.HYPERPRO.COM for the latest pictures, modifications, specs. and e-drawings of this steering damper kit.

HYPERPRO

STEERING DAMPER MOUNTING KIT

for

APRILIA RSV1000 MILLE R Model 2006>

MK-AP10-0005 INSTALLATION INSTRUCTIONS

In general:

HYPERPRO can not be held responsible in any way for any form of physical, material, financial or other damage arising from use, assembly or overhaul of HYPERPRO products. HYPERPRO reserves the right to make changes without prior notice.

This product is ONLY TO BE INSTALLED BY A PROFESSIONAL MECHANIC.

This product is only to be used for the motorcycle brand, model and year stated specifically on top of the pages of this manual.

DO NOT attempt to install this product on motorcycles from any different brand, model and/or year than stated on the pages of this manual.

DO NOT use this kit for cars, boats, jet-skies, snowmobiles, ATV's, aircraft, hovercrafts or any other vehicle and/or purpose.

HYPERPRO steering dampers are FOR RACE USE ONLY, NOT FOR HIGHWAY USE!

Before installation:

- Please read the entire manual carefully before starting the installation!
- Check if you have all the tools required. Good tools are a must.
- Protect your bike at the most important places in and around the work area (e.g. tank, fairing, frame, etc.) with a blanket, towel or similar.

During installation:

- Check all operations and parts carefully before, during and after performing each step.
- Clean all surfaces that are required for fitting parts together or for applying self adhesives or loctite, thoroughly with contact cleaner or another degreaser, unless otherwise stated.
- Be careful not to damage or scratch any part of your bike.
- ALWAYS work relaxed and concentrated!! It is very easy to damage something or make a mistake.

After installation:

- Check and make sure that there is no contact between any part of the steering damper kit and any part of the motorcycle. The kit should not hit anything. Steering movement should not be limited by the steering damper. If the steering movement is limited, adjust the position of the tube in the clamp until steering movement is normal again. Do not forget to tighten the clamp bolt again!
- ALWAYS check the steering movement and feeling before each ride !
- FIRST RIDES: Start with the damper turned fully open (turn adjuster knob fully counter clockwise). Start adjusting in between rides with steps of MAX. 2 CLICKS (0.25 TURN) EACH TIME, until the damper is working satisfactory for your riding style.
- NEVER USE MAXIMUM SETTING, ALWAYS OPEN AT LEAST 2 CLICKS (0.25 TURN).

- WARNING ! DAMPER HAS AN ACTIVE / SPEEDSENSITIVE DAMPING SYSTEM;
 - Steering with NORMAL MOVEMENT should be FREE !!
 - Steering with FAST MOVEMENT should be CONTROLLED BY DAMPER !!
- HYPERPRO uses a special seal to reduce friction. The seal uses an oil film to work properly. It is normal that some oil can appear on the pistonrod.
- Damper works with oil: DAMPING CAN BE HARDER AT LOWER TEMPERATURES!

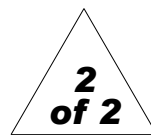

Step 1: Damper clamp pre-assembly

Pre-assemble the clamps onto the damper using:

- Steering damper [stroke 75mm] (4)
- Fork clamp (1)
- Washer M8 (2)
- 1x O-Ring (3)
- Bolt M8x25 Button head (5)
- Damper clamp Type 7 (6)

Loosen the clamp bolt (6a) of the damper clamp (6) and shove it carefully over the steering damper's tube (1). Make sure it is assembled according to the pictures on page 1. Position the clamp at distance "X" (=57mm) and the damper body at the correct angle, then tighten the clamp bolt with a torque of approximately 6Nm/53Lbs.In/4.4Lbs.Ft.

Disassemble the fork clamp. Fit clamp part 1 (6) to the ball joint of the steering damper (4) using the M8x25 bolt (5), O-Ring (3) and washer (2). Make sure it is assembled according to the pictures on page 1. Tighten the M8 bolt (5) with a torque of approx. 14-17Nm/124-150Lbs.In/10.3-12.5Lbs.Ft.

Step 2: fitting the damper to the frame

Install the damper pre-assembly using:

- Damper pre-assembly (from Step 1)
- Bolt M6x30 (7)
- Washer M6 \varnothing 18 (8)
- 2x Washer M6 \varnothing 12 (9, 11)
- 1x O-Ring (10)

Remove the black plastic cover from the bottom of the lower triple tree, providing access to the bottom of the cockpit frame. Use the bolt M6x30 (7) and all parts stated (# 8, 9, 10 & 11), in the correct order (see picture on page 1), to install the damper clamp + damper to the front fairing subframe. APPLY LOCTITE (OR SIMILAR) ON THE THREAD OF THE M6 BOLT. Tighten the bolt with a torque of approximately 6Nm/53Lbs.In/4.4Lbs.Ft.

Step 3: installing the fork clamp

Install the fork clamp onto the fork using:

- Fork clamp assembly(1)

Turn the handlebars of the bike fully to the Right. Make sure that the furthest M8 hole is on the outside and reassemble the fork clamp around the left fork leg (as shown on page 1). Make sure that the clamp is parallel to the riding direction. Height should be set at approx. 7mm above the lower triple tree. Once positioned correctly, fully tighten the bolts (1a) with a torque of approx. 8Nm/70Lbs.In/5.9Lbs.Ft. Check if the bike can make it's full steering angle from left to right, without being obstructed by the damper. If necessary re-position the clamp and re-tighten the bolts.

See WWW.HYPERPRO.COM for the latest pictures, modifications, specs. and e-drawings of this steering damper kit.